

## Light, adjustable, rugged

Light, strong, corrosion-resistant

### Overview

The CM106BE is a general purpose tripod that can be used for mounting sensors, solar panels, antennas, and instrument enclosures. It is constructed from galvanized steel, with

individually adjusted legs that allow installation over uneven terrain. Height of the mast is 2.1 m (7 ft), or 3 m (10 ft) with the mast extension.

### Benefits and Features

- › Support for meteorological sensors, hydrological sensors, sensor mounts, solar panels, environmental enclosures
- › Portable instrument mount
- › Ease of assembly, while maintaining high performance standard
- › Lightning and grounding rods, grounding cables, grounding cable clamps, ground stakes, and UV-resistant cable ties included
- › Enclosures can be mounted on tripod leg, as well as mast
- › Enclosures mount higher on the leg

### Technical Description

The CM106BE includes lightning and grounding rods, grounding cables, UV resistant cable ties, mast extension kit, and stakes for securing the tripod feet to the ground. An optional guy kit is recommended for sites that may experience high wind speeds. Instrument enclosures can be purchased with mounting brackets that attach to either the mast or leg base.

The CM106BE can be used for a variety of applications. For meteorological stations, sensors are mounted to the tripod using mounting brackets appropriate for the model of sensor. For non-meteorological applications, the tripod can be used to mount instrument enclosures, solar panels, junction boxes, or antennas.

## Specifications

- › Measurement Height
  - Upper Mast Retracted: 2.1 m to 2.8 m
  - Upper Mast Extended: 3 m to 3.7 m
- › Vertical Load Limit: 200 kg
- › Mast Outer Diameter
  - Main Lower: 48.0 mm
  - Retractable Upper: 42.50 mm
- › Base Diameter: 2.7 m to 3.5 m
- › Levelling Adjustment: Slide collars on each leg adjust individually
- › Leg Base: 118 mm by 140 mm with four 16 mm holes for stakes
- › Portability: Collapsible to 200 mm diameter by 1850 mm length
- › Maximum Slope Angle:<sup>a</sup> 45°
- › Weight with Mast: 24.5 kg
- › Maximum Allowable Wind<sup>b</sup>

Tripod Configuration	Sustained Wind	Wind Gust
Mast Extended, Unguyed	28 m s <sup>-1</sup> (62 mph)	36 m s <sup>-1</sup> (81 mph)
Mast Retracted, Unguyed	36 m s <sup>-1</sup> (80 mph)	46 m s <sup>-1</sup> (104 mph)
Mast Extended, Guyed	45 m s <sup>-1</sup> (102 mph)	59 m s <sup>-1</sup> (132 mph)
Mast Retracted, Guyed	55 m s <sup>-1</sup> (122 mph)	71 m s <sup>-1</sup> (159 mph)

## Ordering Information

### Tripod

**CM106BE** 2.1 m (7 ft) or 3 m (10 ft) galvanized-steel tripod with grounding kit

### Common Accessory

**009131** Optional tripod guy kit for the CM106BE

**001831** Spare ground pin/stake (x1)

<sup>a</sup>Maximum slope angle specification assumes the feet are adequately fixed to the ground (this may require additional ground stakes or weights). It also assumes that one leg points downhill while the other two legs point uphill.

<sup>b</sup>Allowable wind speed values assume an ENC14/16 enclosure mounted to leg; an SP10 solar panel mounted at the mast base; sensors with a 0.13 m<sup>2</sup> (1.4 ft<sup>2</sup>) projected area that's mounted at the mast top; guy wires attached to mast at 1.1 m (3.8 ft) above tripod body; and adequate ground anchors (stakes alone may not resist foot vertical pullout force); see Appendix A of CM106BE manual for more information on maximum allowable wind speeds).

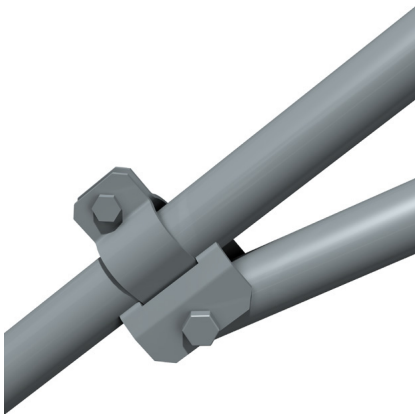

A close up of the adjustable leg clamp

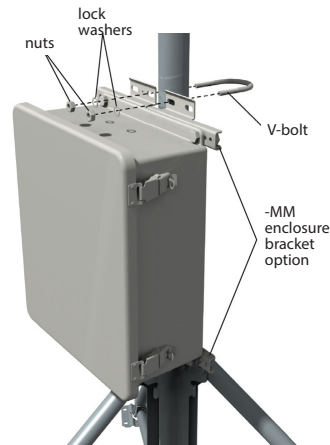

An enclosure mounted to the mast of the CM106BE

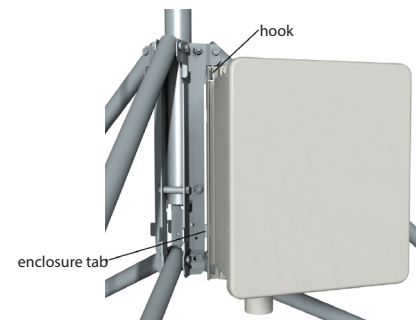

An enclosure mounted to the leg base of the CM106BE